



Oxford Cambridge and RSA

Monday 22 May 2023 – Morning

**GCSE (9–1) Combined Science
(Chemistry) A (Gateway Science)**

J250/09 Paper 9 (Higher Tier)

Time allowed: 1 hour 10 minutes



You must have:

- a ruler (cm/mm)
- the Data Sheet for GCSE (9–1) Combined Science (Chemistry) A (inside this document)

You can use:

- a scientific or graphical calculator
- an HB pencil



Please write clearly in black ink. **Do not write in the barcodes.**

Centre number

--	--	--	--	--

Candidate number

--	--	--	--

First name(s)

Last name

INSTRUCTIONS

- Use black ink. You can use an HB pencil, but only for graphs and diagrams.
- Write your answer to each question in the space provided. If you need extra space use the lined pages at the end of this booklet. The question numbers must be clearly shown.
- Answer **all** the questions.
- Where appropriate, your answer should be supported with working. Marks might be given for using a correct method, even if your answer is wrong.

INFORMATION

- The total mark for this paper is **60**.
- The marks for each question are shown in brackets [].
- Quality of extended response will be assessed in questions marked with an asterisk (*).
- This document has **20** pages.

ADVICE

- Read each question carefully before you start your answer.

2

Section A

You should spend a **maximum** of **20 minutes** on this section.

Write your answer to each question in the box provided.

1 Which substance is described as **pure** by a scientist?

- A A solution of sodium chloride
- B An alloy
- C Dilute sulfuric acid
- D Distilled water

Your answer

[1]

2 A metal oxide has the formula X_2O , where **X** is a Group 1 metal.

The relative formula mass of the metal oxide is 94.2.

Relative atomic mass (A_r): O = 16.0

What is the name of **X**?

- A Lithium
- B Potassium
- C Rubidium
- D Sodium

Your answer

[1]

3

3 Which gas bleaches damp litmus paper?

- A Carbon dioxide
- B Chlorine
- C Hydrogen
- D Oxygen

Your answer

[1]

4 Copper carbonate reacts with dilute hydrochloric acid to form copper chloride, water and a gas.

What is the formula of the gas?

- A C
- B CO
- C CO₂
- D CO₃

Your answer

[1]

5 Which row lists the material that has the weakest **intermolecular** forces?

Material	Structure	Melting point (°C)
A	giant covalent	1713
B	ionic compound	801
C	metal	98
D	polymer	105

Your answer

[1]

4

6 Which diagram shows the correct equipment diagram for simple distillation?

A

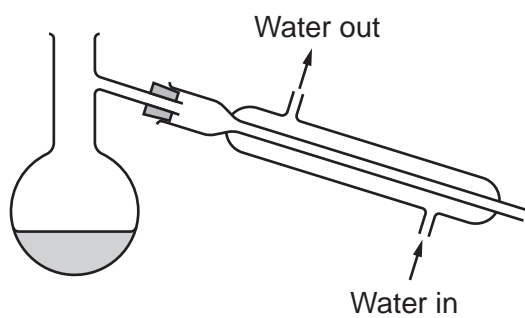

B

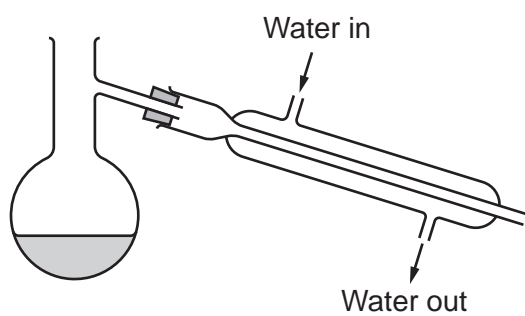

C

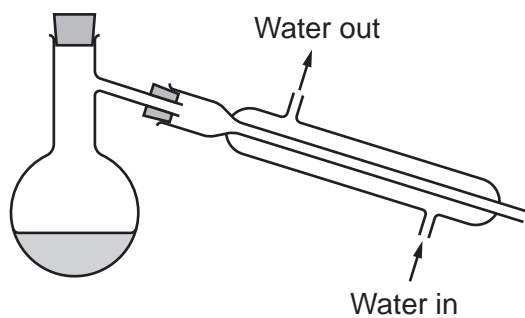

D

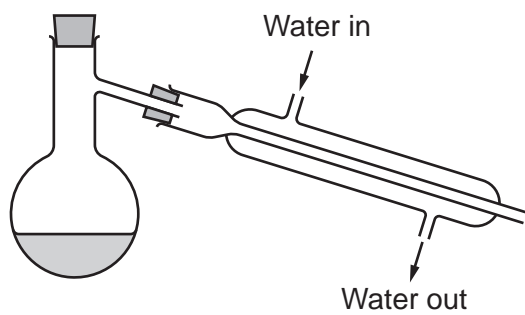

Your answer

[1]

5

7 Which scientist developed this model of the atom?

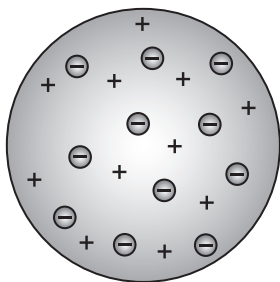

- A Bohr
- B Dalton
- C Rutherford
- D Thomson

Your answer

[1]

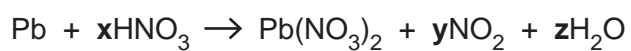
8 Lead, Pb, and dilute nitric acid, HNO_3 react.

Which row correctly balances the equation?

	x	y	z
A	2	4	2
B	4	2	4
C	4	2	2
D	4	4	2

Your answer

[1]

9 This is the symbol for helium.

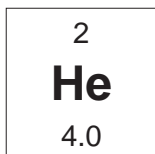

What is the mass of one atom of helium?

The Avogadro constant = 6.02×10^{23}

- A 3.32×10^{-24} g
- B 6.64×10^{-24} g
- C 1.51×10^{23} g
- D 3.01×10^{23} g

Your answer

[1]

10 The diagram shows the particle model for the condensation of a gas into a liquid.

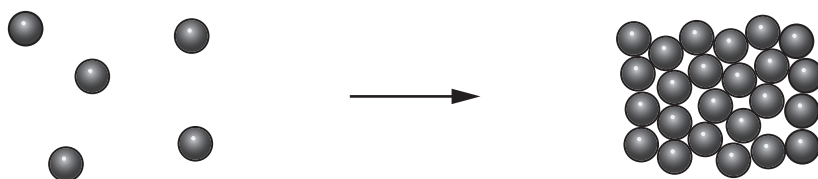

Which is a limitation of the particle model?

- A It does not show the arrangement of the particles.
- B It does not show the movement of the particles.
- C It does not take account of the energy of the particles.
- D It does not take account of the forces between particles.

Your answer

[1]

7
BLANK PAGE

PLEASE DO NOT WRITE ON THIS PAGE

Section B

- 11 Atoms of the same element can have different structures.

Fig. 11.1 shows the structure of two different atoms, Y and Z, of the same element.

Fig. 11.1

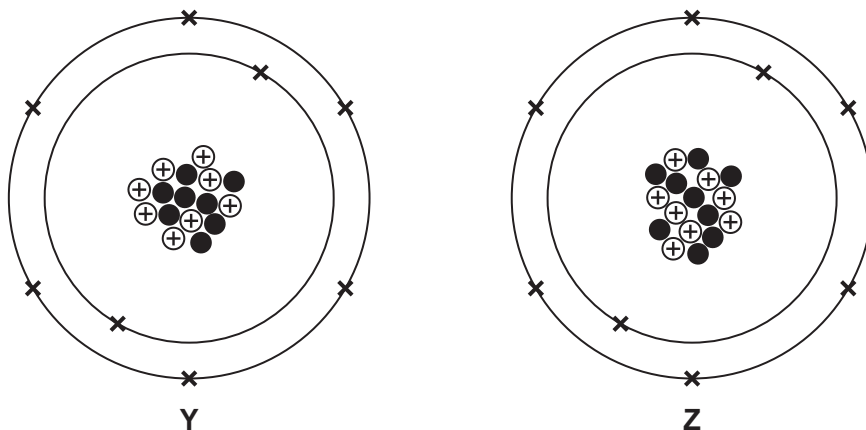

- (a) What name is given to different atoms of the same element such as Y and Z?

..... [1]

- (b) Write the number of protons, neutrons and electrons in an atom of Z.

Number of protons =

Number of neutrons =

Number of electrons =

[2]

- (c) Write the **mass number** of an atom of Z.

Mass number of an atom of Z = [1]

- (d) Write the name of the element that contains atoms of Y and Z.

Use the Periodic Table.

..... [1]

(e) Atoms of sodium react with atoms of **Y** to form an ionic compound.

Fig. 11.2 shows the ions formed when an atom of sodium reacts with an atom of **Y**.

Fig. 11.2

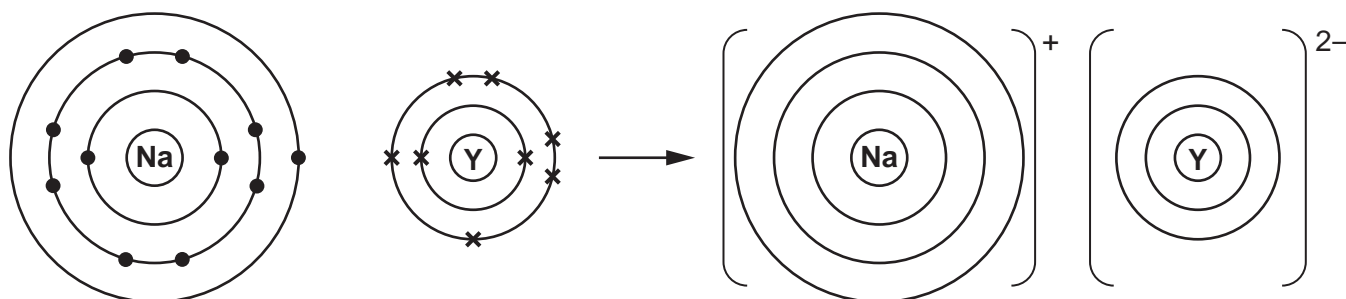

(i) Complete **Fig. 11.2** to show the arrangement of electrons in the ions. [2]

(ii) What is the formula of the ionic compound formed when atoms of sodium react with atoms of **Y**?

Tick (✓) **one** box.

NaY₂

Na₂Y

Na₂Y₂

[1]

(iii) Why does sodium react with **Y** and **Z** in a similar way?

Tick (✓) **one** box.

Atoms of **Y** and **Z** have the same number of electrons.

Atoms of **Y** and **Z** have the same number of neutrons.

Atoms of **Y** and **Z** have the same number of protons.

[1]

10

(iv) The ionic compound formed in **Fig. 11.2** has a high melting point.

Explain why. Use ideas about structure and bonding.

.....

.....

.....

.....

.....

.....

..... [3]

11
BLANK PAGE

PLEASE DO NOT WRITE ON THIS PAGE

12

12 Thin layer chromatography (TLC) is used to analyse and identify unknown samples.

Fig. 12.1 shows the apparatus used for thin layer chromatography.

Fig. 12.1

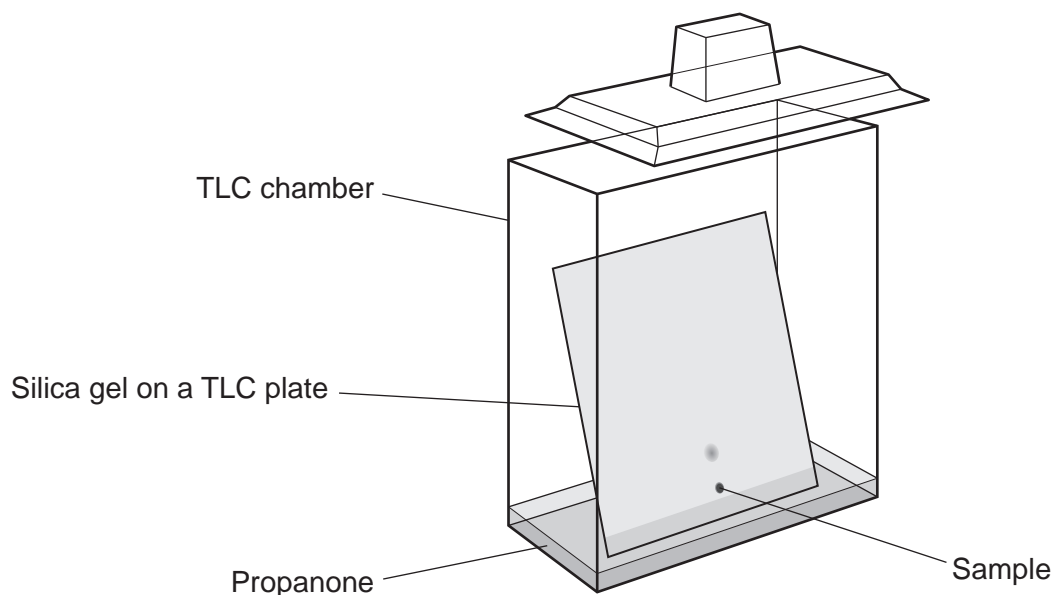

(a) Identify the stationary phase and mobile phase shown in **Fig. 12.1**.

Stationary phase

Mobile phase

[2]

(b) What determines how far the sample travels up the TLC plate?

Tick (✓) **one** box.

The amount of sample used.

The size of the TLC chamber.

The type of solvent used.

[1]

(c) Fig. 12.2 shows the final TLC plate for a sample.

Fig. 12.2

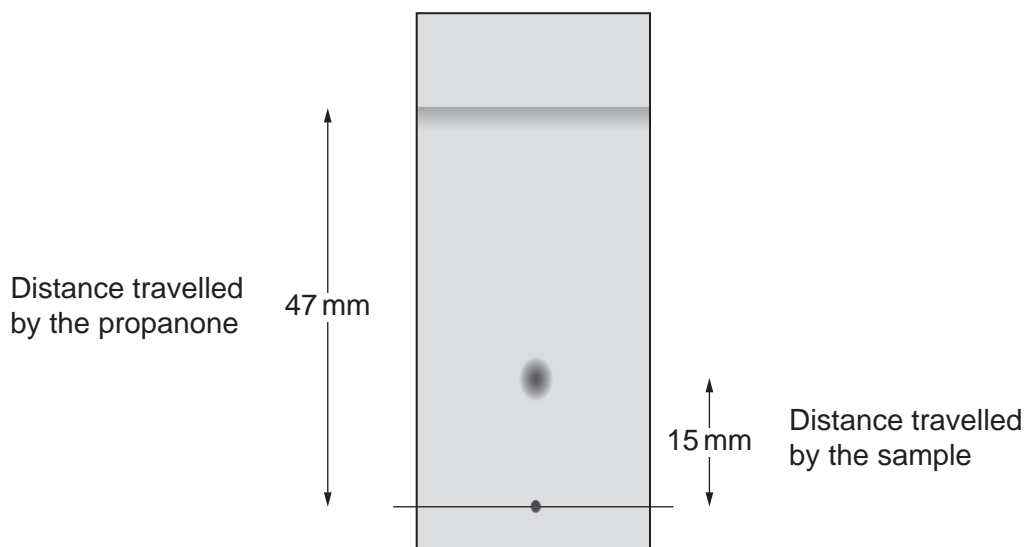

(i) Calculate the R_f value for the sample.

Give your answer to 2 decimal places.

R_f value for sample = [3]

(ii) The table shows the R_f values for four different substances.

Substance	R_f value
A	0.23
B	0.57
C	0.30
D	0.18

Use your answer to (i) to identify which substance, A, B, C or D, is the sample.

Tick (✓) **one** box.

The sample is substance A B C D

[1]

13 Diamond and graphite are different forms of the same element.

The diagrams show the structures of diamond and graphite.

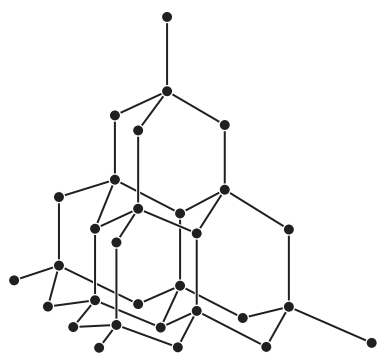

Diamond

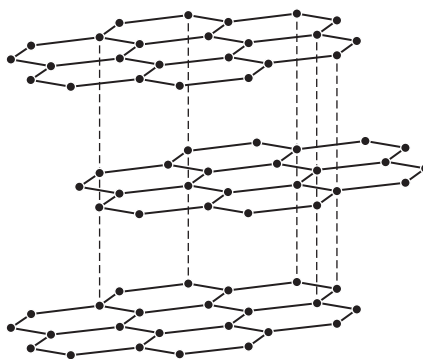

Graphite

(a) Describe and explain **one** property of graphite that is **different** from diamond.

Property

Explanation

.....

 [3]

(b) Describe and explain **one** property that is **similar** for both diamond and graphite.

Property

Explanation

.....

 [3]

(c) A student thinks that the models used to represent diamond and graphite have limitations.

Give **one** reason why they are **correct**.

.....
 [1]

15

14* Copper sulfate solution, CuSO_4 , contains copper ions, Cu^{2+} , and sulfate ions, SO_4^{2-} .

A student extracts copper from copper sulfate solution using electrolysis.

They use the following equipment:

- a power pack
- a small glass beaker
- crocodile clips
- carbon electrodes
- wires.

Describe and explain how the student extracts copper from the copper sulfate solution using the equipment provided.

Include a labelled diagram of how the equipment is used.

.....

.....

.....

.....

.....

.....

.....

.....

.....

.....

.....

.....

.....

.....

.....

.....

.....

.....

.....

.....

.....

.....

[6]

15 (a) Describe the difference between a strong acid and a weak acid.

.....
 [1]

(b) Hydrochloric acid, $\text{HCl}(\text{aq})$, is an example of a strong acid.

The graph shows the pH of a dilute hydrochloric acid solution at different concentrations.

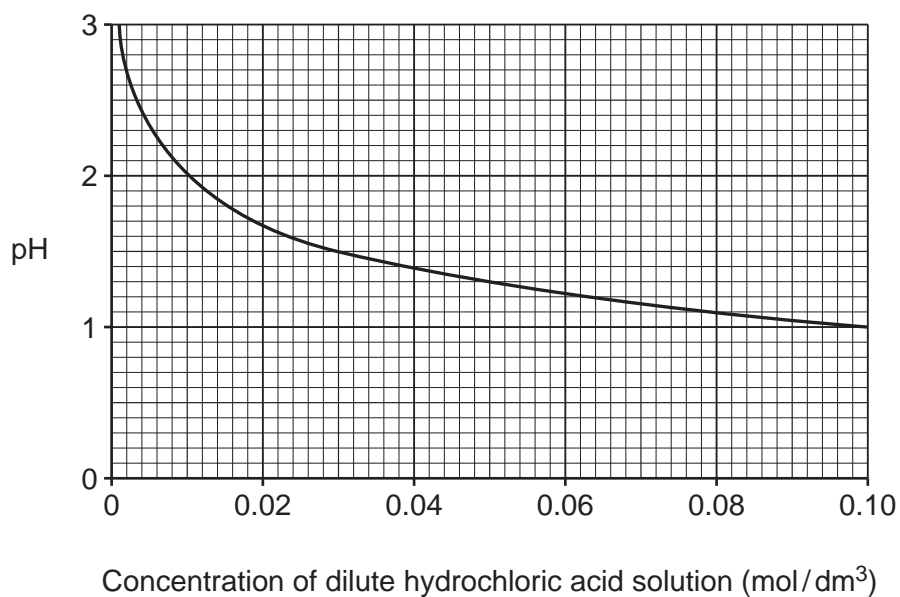

(i) Write the formula of the ion that gives the dilute hydrochloric acid solution the pH shown on the graph.

..... [1]

(ii) The pH of the dilute hydrochloric acid solution can be measured using either universal indicator or a pH meter.

Explain which method would be better to use for measuring the pH shown on the graph.

.....

 [2]

- (c) Describe how the pH changes with the concentration of dilute hydrochloric acid solution on the graph.

.....
.....
.....
.....

[2]

- (d) As the concentration of the dilute hydrochloric acid solution increases by a factor of ten, the pH of the solution decreases by one.

Use data from the graph to show that this statement is **true**.

.....
.....
.....
.....

[2]

- (e) Calculate the mass of hydrochloric acid, HCl, in 100 cm³ of solution that gives a pH 1.5.

Use data from the graph.

Give your answer to **2** significant figures.

Relative molecular mass (M_r): HCl = 36.5

Mass of hydrochloric acid in 100 cm³ = g [4]

18

- 16 The reaction between nitrogen, N_2 , and hydrogen, H_2 , to form ammonia, NH_3 , is an exothermic reaction which is shown in this equation.

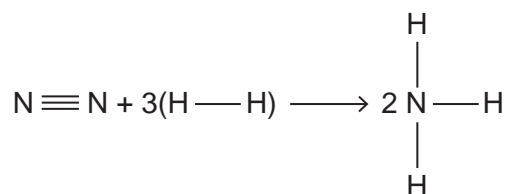

The table shows some bond energies.

Bond	Bond energy (kJ/mol)
$N \equiv N$	945
$H - H$	435
$N - H$	390

- (a) (i) Calculate the total energy transferred to break all the bonds in the reactants.

Energy transferred to break all the bonds = kJ/mol [1]

- (ii) Calculate the total energy transferred when all the bonds in the products are made.

Energy transferred when all the bonds are made = kJ/mol [1]

- (iii) Use your answers to parts (i) and (ii) to calculate the energy change for the reaction.

Energy change = kJ/mol [1]

19

- (b) Complete the reaction profile for the exothermic reaction of nitrogen, N_2 , and hydrogen, H_2 , to form ammonia, NH_3 .

Label the energy change in the reaction and the activation energy.

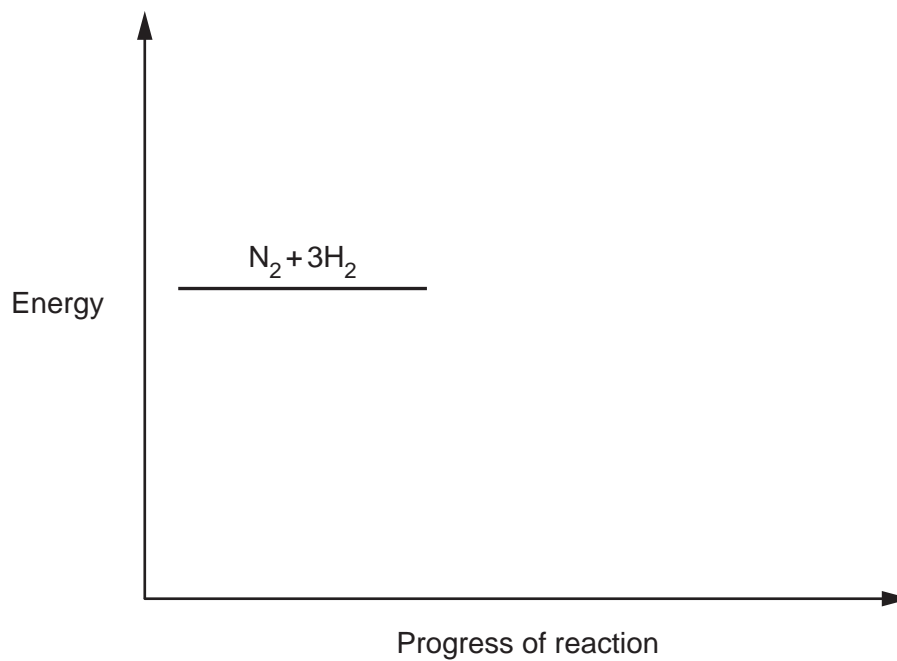

END OF QUESTION PAPER

[3]

ADDITIONAL ANSWER SPACE

If additional space is required, you should use the following lined page(s). The question number(s) must be clearly shown in the margin(s).

A large rectangular area with a solid vertical line on the left side and horizontal dotted lines across the rest of the page, providing space for writing answers.



Copyright Information

OCR is committed to seeking permission to reproduce all third-party content that it uses in its assessment materials. OCR has attempted to identify and contact all copyright holders whose work is used in this paper. To avoid the issue of disclosure of answer-related information to candidates, all copyright acknowledgements are reproduced in the OCR Copyright Acknowledgements Booklet. This is produced for each series of examinations and is freely available to download from our public website (www.ocr.org.uk) after the live examination series.

If OCR has unwittingly failed to correctly acknowledge or clear any third-party content in this assessment material, OCR will be happy to correct its mistake at the earliest possible opportunity.

For queries or further information please contact The OCR Copyright Team, The Triangle Building, Shaftesbury Road, Cambridge CB2 8EA.

OCR is part of Cambridge University Press & Assessment, which is itself a department of the University of Cambridge.